

WHY CHOOSE SATAKE

SATAKE was founded in 1920, currently the No. 1 agitator manufacturer in Japan. SATAKE agitator is well-known as its **Quality, Efficient, Innovation, Robust Performance & Long-Life Service.**

SMALL & LIGHTWEIGHT	Compact, user-friendly & handy design for easy install & easy-use.
HIGH PERFORMANCE IMPELLER	High mixing efficiency at low power consumption for energy-saving.
ENGINEERING PLASTIC GEAR	Reduce noise particularly for A720 & AT-G, lubrication-free & maintenance-free.
FREE CHOICE OF MATERIAL	Wetted parts can be customized to anti-corrosion metal, rubber lining, resin coating, etc.
FULL RANGE OPTIONS	To enhance the product quality, operation efficiency & safety.

APPLICATION INDUSTRY



SATAKE
MultiMix (M)

CONTACT US

-  27, Jalan Meranti Puchong, D'25 @ Meranti Puchong, 47120 Puchong, Selangor, Malaysia.
-  +603-3310 0888
+6017-358 9980 (WA business)
-  info@satakemultimix.com.my
-  satakemultimix.com.my



Scan to get
E-Brochure



SATAKE
MultiMix (M)

PRODUCT CATALOG

- PORTABLE MIXER
- MULTI A MIXER



CAT. No.-AP • AT-'23 (000)

CLAMP TYPE

PORTABLE MIXER: A710

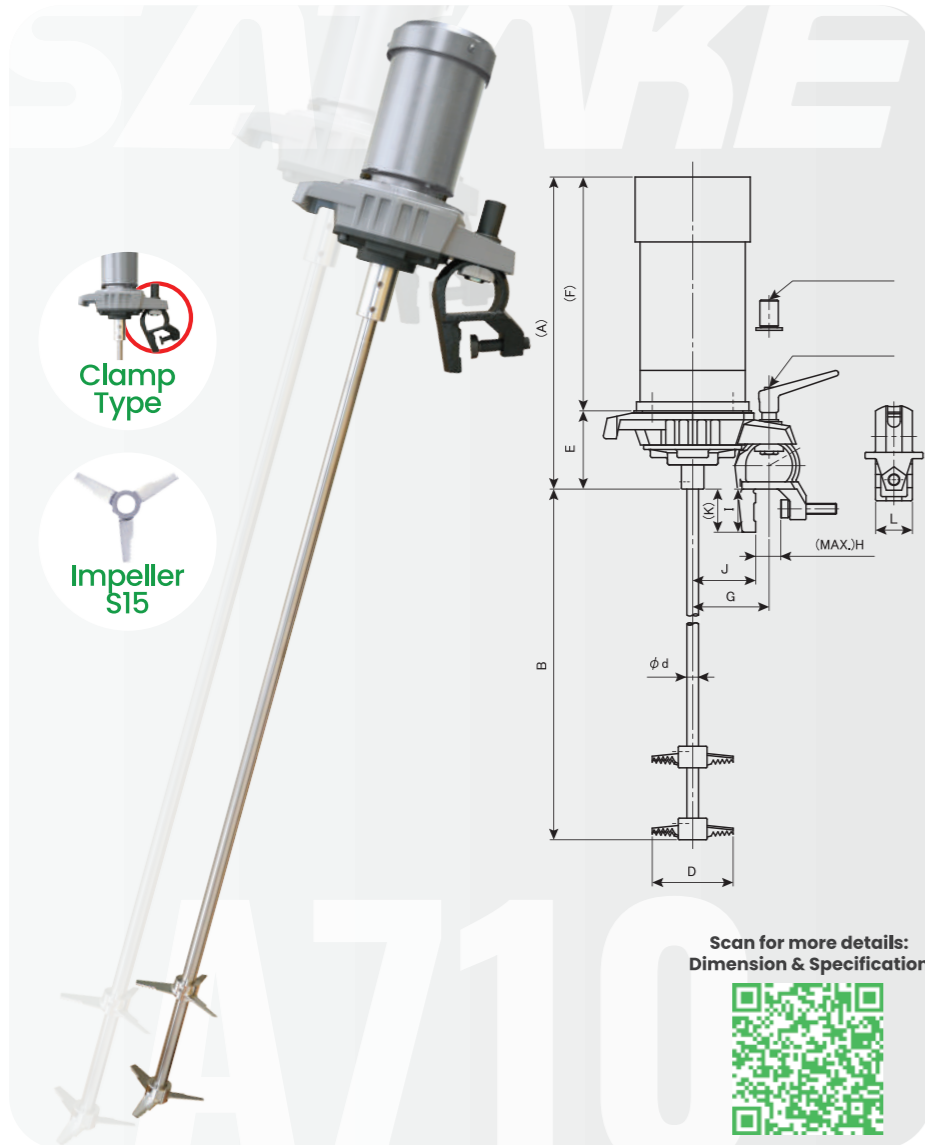

SPECIFICATION

- High Shear with S15 impeller (exclusive for A710) for Efficient Mixing, Dissolve, Disperse and Break Down.
- Saw teeth design at the tip blade to break down solids.
- SUS304 & SUS316 for standard material of wetted parts.
- 3-phase T.E.F.C. Motor: 220-240V or 380-415V.
- Single-phase 220-240V with Inverter as optional.
- 0.75kW & 1.5kW motor power option available.

SPECIAL SERVICE: CUSTOM MADE

The product can be custom-made accordingly to meet customer requirements with FREE technical consultation.

CLAMP TYPE

PORTABLE MIXER: A720/A720-K

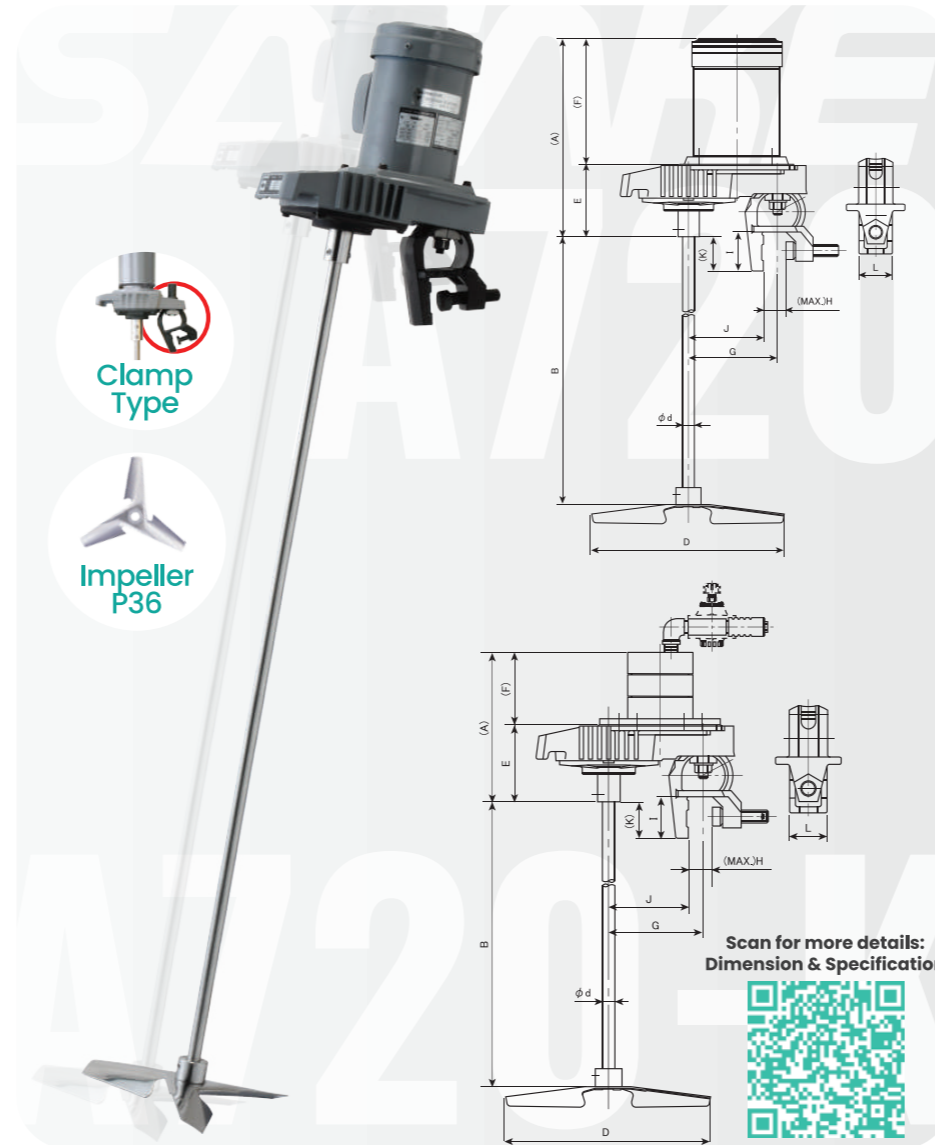

SPECIFICATION

- Exclusive P36 impeller for A720 & AT-G series built with camber & rake angle blade to perform high efficiency axial flow.
- Ensures high mixing performance for general application of soluble liquid-liquid & solid-liquid mixing.
- A720-K with explosion-proof design driven by air-motor for safety-purpose.
- A720-K specifically designed for liquid-liquid mixing containing organic solvents that can ignite or explode.

SPECIAL SERVICE: LOCAL ASSEMBLY

Local assembly with Japan standard to ensure delivery within a short period of time. (Delivery: 7-14 days)
Spare parts are readily available, as well.

FLANGE TYPE

MULTI A MIXER: AT-G

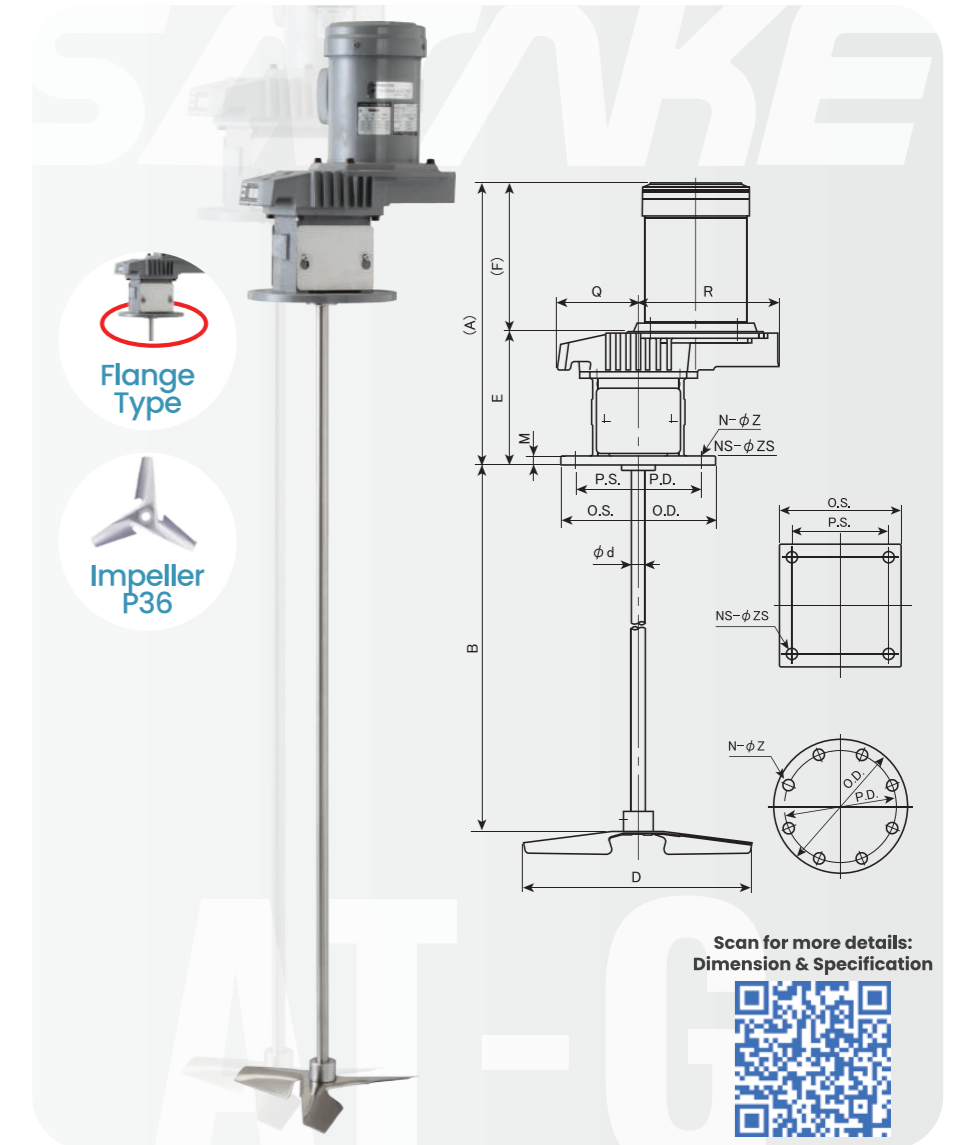

SPECIFICATION

- Oil Seal & Gland Packing Seal are available for general application.
- Dry Mechanical Seal which is ideal for Food, Pharmaceutical and Chemical also available.

Oil-Seal Gland Packing Dry Mechanical Seal

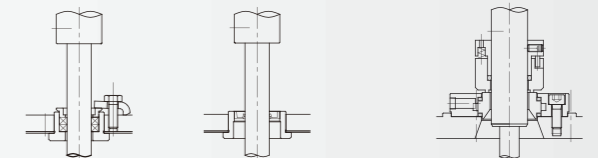

MOUNTING UNIT



Spring Balancer Stand
Easy maintenance without lubricant.



Hydraulic Stand
Foot-operated oil pump for operation.